

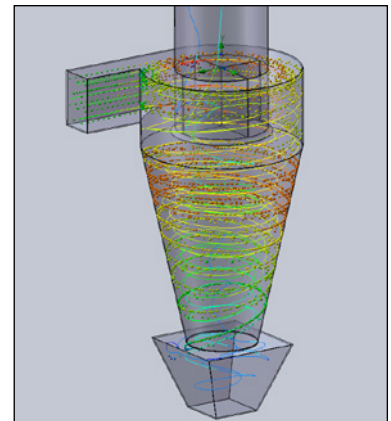

**Standard for clean air**

**Discharging coarse, fine and combustible particles while protecting the filter media**



Particle flow inside a cyclone separator

# The appropriate pre-separator for multiple tasks

## The task

Keller pre-separators are used for discharging coarse, fine and combustible particles, protecting the filter media while minimizing wear and tear. Additionally, they collect a larger dust volume while acting as spark pre-separators to help minimize the risk of fire.

## Choice of models

Depending on the required level of pre-separation and the material to be separated, three different types are available

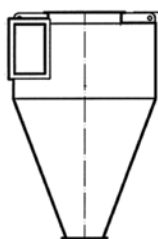

**Material pre-separator MVA**

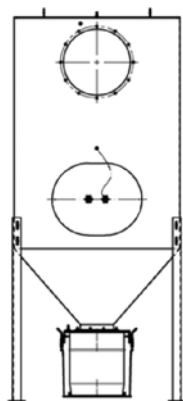

**Impact separator PA**

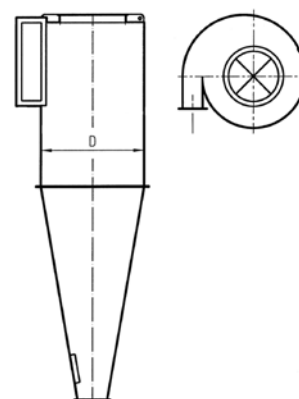

**Cyclone separator AS**



**Advantages of the material pre-separator:** Filter elements are protected, the risk of fire is reduced, compact and low design



**Advantages of the impact separator:** By discharging highly energized sparks, the risk of fire inside the filter is reduced, and the filter elements are largely protected.



**Advantages of the cyclone separator:** Protection of the filter elements, high fractional separation efficiency, more suitable for higher air flows up to 125 000 m<sup>3</sup>/h.

## Material pre-separator MVA, MVAS

### Design

Material pre-separators MVA are available in different materials and consist of:

- Cylindrical upper section with openings for dirty and clean air
- Funnel-shaped lower section with a spiral deflector

**MVAS** = reinforced construction

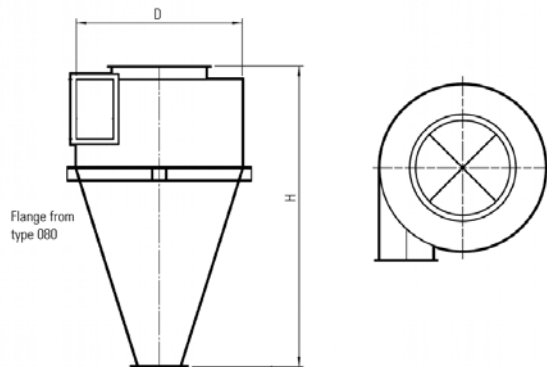

### Operation

Mechanical separators operate according to the principle of centrifugal force. Dirty air enters the cylindrical chamber of the spark pre-separator

through an external inlet. The dust particles are propelled against the outer wall and spiraled downward to the funnel-shaped discharge. Clean

air exits the spark pre-separator through the top.

### Technical data for material pre-separator

Type		045	050	056	063	071	080	090	100	112	125	140	160	180	200
Diameter (D)	mm	800	900	1000	1120	1250	1400	1600	1800	2000	2240	2500	2800	3150	3550
Height (H)	mm	1500	1670	1800	2010	2225	2500	2820	3190	3500	4010	4400	4960	5595	6275
Weight (MVA)	kg	75	95	120	135	180	235	300	355	410					
Weight (MVAS)	kg	145	180	225	260	350	450	470	608	900	1020	1960	2350	3190	3660
Pressure differential $\Delta p = 90$ daPa	Thousand	3,2	4	5	6	8	10	12,5	16	20	25	32	40	50	63
Air flow	m <sup>3</sup> /h														

Subject to modifications

## Impact separator PA

Compact impact separator for discharging e.g., sparks, available in a variety of materials, and for direct attachment to filter systems.

### Operation

The dirty air enters the pre-separator at the top and is deflected into the hopper area. If sparks are introduced, the thermal energy of the particles is diminished and large particles are separated. Disposal is in a bucket mounted underneath. The cleaned air is discharged out the rear exhaust.

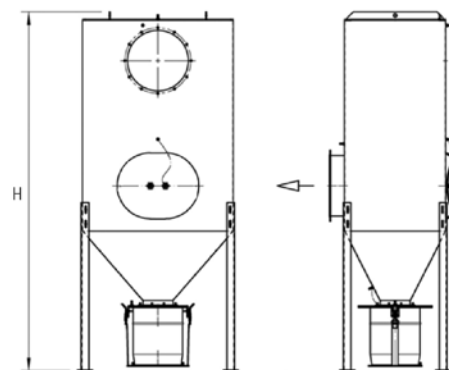

### Technical data Impact separator

Type		PA 1	PA 2	PA 3	PA 4	PA 5	PA 6
Max. air flow	m <sup>3</sup> /h	3000	7000	10000	14000	20000	22000
Pressure loss <sup>1)</sup>	daPa	80	80	80	60	60	60
Length	mm	770	1065	1365	1555	2400	2400
Width	mm	690	735	865	1010	1000	1000
Height (H)	mm	2100	2400	3065	3110	2835	3237

<sup>1)</sup> at max. air flow

Subject to modifications

## Cyclone separator AS, ASS

### Design

High performance cyclone separators are available in different materials and consist of:

- Cylindrical upper section with openings for dirty and clean air
- Conical lower section with discharge outlet

**ASS** = reinforced version

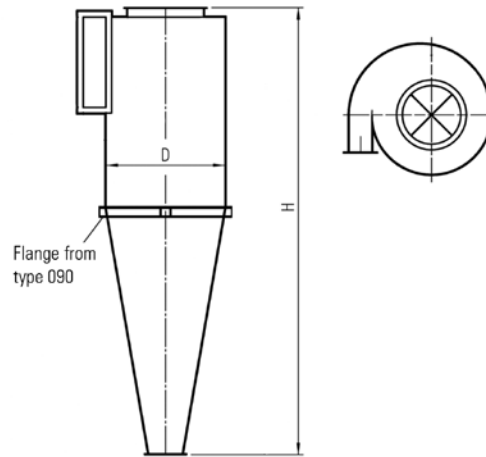

### Operation

Mechanical separators operate according to the principle of centrifugal force. Dirty air enters the cylindrical part of the cyclone through the ad-

joining intake. The dust particles are propelled against the outer wall and spiralled downwards through the funnel-shaped discharge. The cleaned

air exits the cyclone through an upper exhaust air outlet.

### Dimension sheet

#### Cyclone pre-separator

Type		40	45	50	56	63	71	80	90	100
Diameter (D)	mm	630	710	800	900	1000	1120	1250	1400	1600
Height (H)	mm	2275	2875	2975	3380	3735	4310	4700	5210	5580
Weight (AS)	kg	100	140	158	190	246	315	377	480	545
Weight (ASS)	kg	142	183	221	265	450	660	760	823	1037
Pressure differential		Air flow [m³/h]								
$\Delta p = 63$	daPa	2500	3150	4000	5000	6300	8000	10000	12500	16000
$\Delta p = 80$	daPa	2800	3550	4500	5600	7100	9000	11000	14000	18000
$\Delta p = 100$	daPa	3150	4000	5000	6300	8000	10000	12500	16000	20000

Other versions available (up to 125 000 m³/h)

Subject to modifications

### Keller Lufttechnik GmbH + Co. KG

Neue Weilheimer Str. 30  
73230 Kirchheim unter Teck  
Fon +49 7021 574-0  
info@keller-lufttechnik.de  
keller-lufttechnik.de